

## FITTING INSTRUCTION

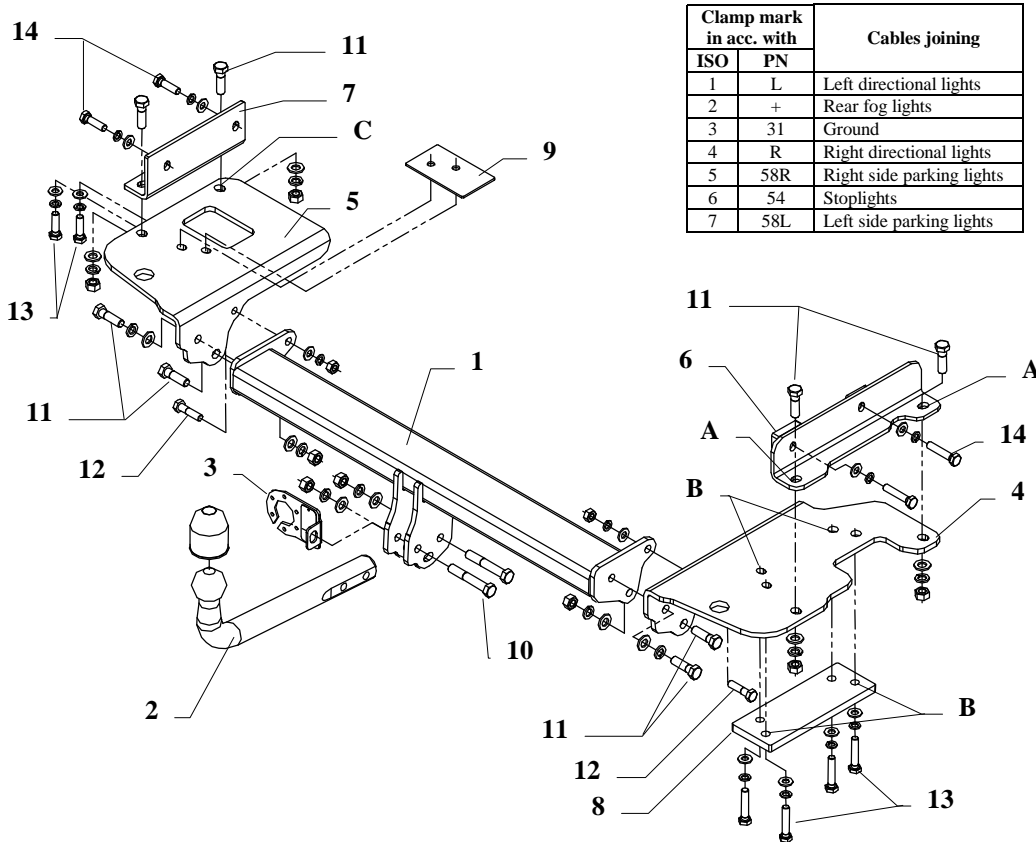

Clamp mark in acc. with		Cables joining
ISO	PN	
1	L	Left directional lights
2	+	Rear fog lights
3	31	Ground
4	R	Right directional lights
5	58R	Right side parking lights
6	54	Stoptlights
7	58L	Left side parking lights

## The instruction of the assembly

1. Remove four plastic plus from the underside of the bumper.
2. On the right side of the car remove original towing eye unit and cut him out according to figure 2.
3. On the left side untwist, from the left chassis member, one (of two) bolt (farther from rear of the car). This bolt will be not used any more.
4. Take out the muffler unit from the last three holders, guard against fall.
5. From outside of the right chassis member put right fish-plate (pos. 6) and fix it to the member by bolts M10x1,25x35mm (pos. 14) – see figure 1.
6. To fixed fish-plate (pos. 6) fix loosely right bracket (pos. 4) through holes A using bolts M12x40mm (pos. 11).
7. Fix original towing eye through holes B using bolts M10x1,25x50mm (pos. 13), remember about distance plate (pos. 8).
8. From outside of left chassis member put left fish-plate (pos. 7) and fix it to the member by bolts M10x1,25x35mm (pos. 14)
9. To fixed fish-plate (pos. 7) fix loosely left bracket (pos. 5) through holes C using bolts M12x40mm (pos. 11)
10. Fix loosely left bracket (pos. 5) with member by bolts M10x1,25x50mm (pos. 13) remember about left distance plate (pos. 9).
11. On the underside of the middle of the bumper saw out a fragment measuring 50mm wide and 45mm deep.
12. Between fixed brackets (pos. 4 and 5) put main bar of the towing hitch (pos. 1) and fix it by bolts M12x40mm (pos. 11) and M10x40mm (pos. 12).
13. Fix tow-ball (pos. 2) and socket plate (pos. 3) by bolts M12x75mm (pos. 10) from equipment.
14. Tighten all bolts according to the torque shown in the table.
15. Connect electric wires of 7-pole socket according to the instruction of the car. (Recommend to make at authorized service station)
16. Complete paint layer damaged during installation.

This towing hitch is designed to assembly in following cars:

**KIA SPORTAGE / KM (JE)** produced since 2004 till 07.2010 and **HYUNDAI TUCSON** produced since 2004, catalogue number **T45** and is prepared to tow trailers max total weight **2000 kg** and max vertical load **80 kg**.

### From manufacturer

Thank you for buying our product. Their reliability has been confirmed in many tests. Reliability of towing hitch depends also on correct assembly and right operation. For this reasons we kindly ask to read carefully this instruction and apply to hints.

*The towing hitch should be install in points described by a car producer.*

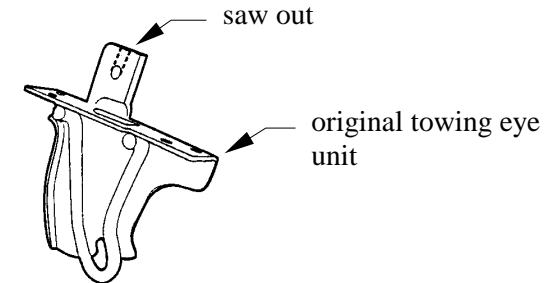

Fig. 2.











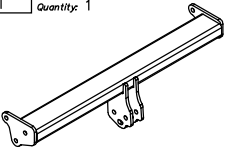
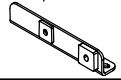

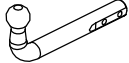



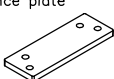

### NOTE

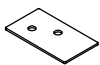
After install the towing hitch you should get adequate note in registration book (at authorised service station).The car should be equipped with:

- Indicators
- Tow mirrors

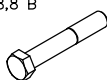
After 1000km of exploitation check all bolts and nuts. The ball of towing hitch must be always kept clear and conserve with a grease.

## Towing hitch accessories:

Pos. 1 Name: Main bar Quantity: 1 	Pos. 6 Name: Right fish-plate Quantity: 1 	Pos. 12 Name: Bolt 8,8 B Quantity: 2 Dim.: M10x40mm 	Pos. 18 Name: Plain washer Quantity: 12 Dim.: Ø 10,5 mm 
Pos. 2 Name: Tow-ball Quantity: 1 	Pos. 7 Name: Left fish-plate Quantity: 1 	Pos. 13 Name: Bolt 8,8 B Quantity: 6 Dim.: M10x1,25x50 	Pos. 19 Name: Spring washer Quantity: 10 Dim.: Ø 12,2 mm 
Pos. 3 Name: Socket plate Quantity: 1 	Pos. 8 Name: Distance plate Quantity: 1 RIGHT 	Pos. 14 Name: Bolt 8,8 B Quantity: 4 Dim.: M10x1,25x35 	Pos. 20 Name: Spring washer Quantity: 12 Dim.: Ø 10,2 mm 
Pos. 4 Name: Right bracket Quantity: 1 	Pos. 9 Name: Distance plate Quantity: 1 LEFT 	Pos. 15 Name: Nut 8 B Quantity: 8 Dim.: M12 	Pos. 21 Name: Ball cover Quantity: 1 
Pos. 5 Name: Left bracket Quantity: 1 	Pos. 10 Name: Bolt 8,8 B Quantity: 2 Dim.: M12x75mm 	Pos. 16 Name: Nut 8 B Quantity: 2 Dim.: M10 	
	Pos. 11 Name: Bolt 8,8 B Quantity: 8 Dim.: M12x40mm 	Pos. 17 Name: Plain washer Quantity: 10 Dim.: Ø 13 mm 	

### Torque settings for nuts and bolts (8,8):

**M6** - 11 Nm      **M8** - 25 Nm      **M10** - 50 Nm  
**M12** - 87 Nm    **M14** - 138 Nm    **M16** - 210 Nm



**PPUH AUTO-HAK Sp.J.**

Produkcja Zaczepów Kulowych  
 Henryk & Zbigniew Nejman  
 76-200 SŁUPSK ul. Słoneczna 16K  
 tel/fax (059) 8-414-414; 8-414-413  
 E-mail: office@autohak.com.pl  
 www. autohak.com.pl

## Towing hitch (without electrical set)

Class: **A50-X**    Cat. no. **T45**  
 Designed for:  
**KIA SPORTAGE / KM (JE)**  
 produced since 2004 till 07.2010 and  
**HYUNDAI TUCSON**  
 produced since 2004

Technical data:  
**D-value: 10,3 kN**  
 maximum trailer weight: **2000 kg**  
 maximum vertical cup load: **80 kg**

Approval number according to Directive 94/20/EC: **e20\*94/20\*0215\*00**

### Foreword

This towing hitch is design according to rules of safety traffic regulations. The towing hitch is a safety component and must be installed only by qualified personnel. Any alteration or conversion to the towinh hitch is prohibited and would lead to cancellation of design certification. Remove insulating compound and underseal from vehicle (if present) in the area of the matting surfaces of the towing hitch.

The vehicle manufacturer's specifications regarding trailer load and max. vertical cup load are decisive for driving, and values for the towing hitch cannot be exceeded.

D-value formula:

$$\frac{\text{Max trailer weight [kg]} \times \text{Max vehicle weight [kg]}}{\text{Max trailer weight [kg]} + \text{Max vehicle weight [kg]}} \times \frac{9,81}{1000} = D \text{ [kN]}$$